

## 1888-1988: A HUNDRED YEARS OF MAGNETIC SOUND RECORDING\*

*Friedrich Karl Engel*

*Vice Chairman, AES Technical Archives Committee, Europe Region Audio Tape Application Engineering Dept., BASF AG, D-6700 Ludwigshafen, FRG*

In the past, the essay "Some Possible Forms of Phonograph" by the American engineer Oberlin Smith, dating from 1888, has been regarded merely as a first indication of the possibility of electromagnetic sound recording. The Danish engineer Valdemar Poulsen has hitherto been considered to be the actual inventor of this method of sound recording. A recently discovered reader's letter proves that Smith constructed a unit with functional transducers, which could at least be used for experimental purposes, and is therefore the inventor of the magnetic sound recording technique.

1888 September 8 saw the publication in the United States of three papers of great significance in the light of later events: the engineer Herman Hollerith's first two patents relating to punch cards for analyzing censuses and similar data [1], and a 2400-word article "Some Possible Forms of Phonograph"[2] by the mechanical engineer Oberlin Smith (Fig. 1). Hollerith's studies are regarded as the origin of modern data processing, while Smith describes an original method for storing sound signals. His article appeared in *The Electrical World*, which at that time was "the world's most widely read technical journal"[3]. In principle, the mechanical storage of speech - or, in more general terms, of sound signals - and its transmission by wire were known in 1888:

- 1) In 1875 Alexander Graham Bell applied for a patent for his telephone, symbolizing communication over any distance without the inevitable restrictions imposed by the telegraph.
- 2) In 1877 Edison invented the phonograph, which for the first time made it possible "to store up and reproduce automatically at any future time" sound, music, and speech (quoted in [4, p.662]).
- 3) In 1887 Emile Berliner launched the "gramophone," the definitive form of mechanical sound recording.

These three inventions heralded the most far-reaching expansion in methods of communication since the invention of letterpress printing. By the same token, the commercial prospects for exploiting this expansion were exceptionally promising. In brief, the stage was set for inventors and new inventions. It says much for the editorial farsightedness of *The Electrical World* that it gave extensive coverage to the *mechanical* recording of sound - even though it prefaced the work of a mechanical engineer, whose description of a "purely *electrical*" version it printed, with a somewhat skeptical editorial note.

What were the processes of thought which led Smith to combine the function of the phonograph - the recording and reproduction of audible phenomena - with the telephone's transducers to obtain a novel recording technique, and in addition to invent a sound storage medium that was appropriate for the system? Let us attempt to reconstruct those processes.



Fig. 1 Oberlin Smith, mechanical engineer from Bridgeton, NJ (1840-1926). The picture probably shows him as president of the American Society of Mechanical Engineers in 1889.

Imagine that speech could be transmitted over a telephone line at a very slow "rate of travel," so that at a particular point in time the entire message would be somewhere in the wire between speaker and listener. If it were possible to "freeze" this situation, the effect would be to store or fix the message, to have recorded it (converting a time function into a place function). In order to bring this about, Smith proposes three "possible forms of phonograph":

- 1) Changing the profile of ribbon-or wire-shaped carrier, which is to be warmed to make it easier to distort; a vertically modulated groove is to be made in the ribbon, in the manner of the Edison phonograph, and the wire is to be indented in the manner of a toothed rack; that is, the plastic pattern of the recording is to be both produced mechanically and read mechanically.

- 2) Changing the "resistance profile" of the carrier, in other words its galvanic conductivity, which is produced mechanically and read electrically (elements of the carbon microphone principle applied to sound recording), that is, the recording forms a resistance pattern.

Smith devoted only a quarter of his article to these two methods; they are dealt with in a somewhat casual manner, and are probably merely intended to demonstrate his familiarity with the problems of mechanical sound recording and to trace the thought processes that led to his actual invention.

- 3) Changing the "magnetic profile" of the carrier, in other words, the magnetic flux in the direction of movement of the carrier, that is, the sound signal is stored in the form of a magnetization pattern. Smith clearly stresses the fundamental novelty:

The following proposed apparatus is...*purely electrical*, and is, as far as known to the writer, the only one fulfilling such conditions that has been suggested. (Italics as in original.)

This wording may be open to attack (the transport of the sound carrier remains a mechanical matter), but on closer inspection the idea is a technological revolution. Smith, in fact, outlines an apparatus which not only contains important assemblies to be found in a modern magnetic tape recorder but also uses, in principle, the same storage procedure - he is inventing magnetic sound recording.

Proof of this can be found in Figs. 2 and 3. D and E are the supply and take-up reels, respectively, for the sound carrier C, and are driven by a clockwork motor (not shown); J is a rudimentary sound carrier tension control; A is the "microphone," in other words, the acoustical-electrical transducer; B is the electrical-magnetic transducer (a magnetizing coil, equivalent to a magnetic head); and F is a battery which supplies the operating voltage.

During recording, the audio frequency currents pass through coil B and generate a magnetic field there, so that a magnetization pattern is formed on the moving sound carrier C, which reflects the sound vibrations. Or, as Smith puts it:

...the current, broken into waves of varying lengths and intensities corresponding with the vibrations of the diaphragm in the telephone, passes in its circuit through the helix B, converting into a permanent magnet any piece of hardened steel which may be at the time within the helix. Through this helix B passes a cord...C, made wholly or partly of hardened steel, and kept in motion by being wound on the reel E from off the reel D... When in operation..., the cord C becomes, so to speak, a series of short magnets.... The actual lengths of these groups depend upon the speed..., but their relative lengths depend upon the relative lengths of the sound wave; and their relative intensities depend upon the relative amplitudes of these waves.

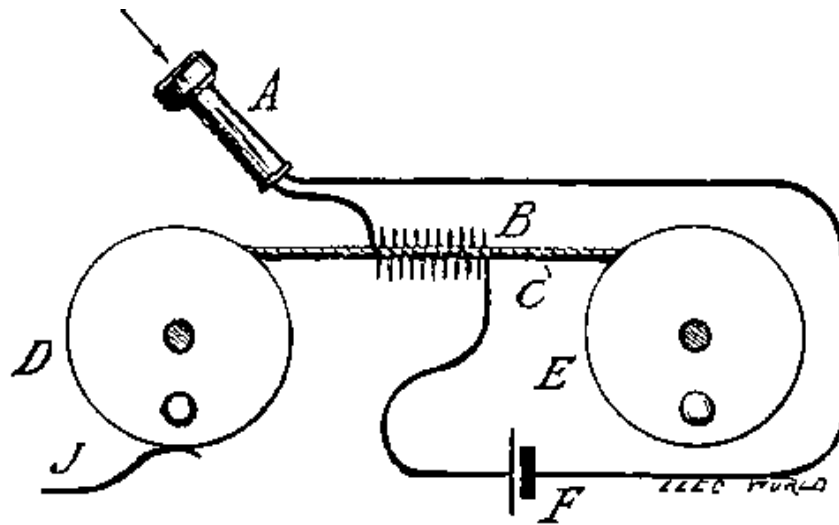

Fig. 2 Smith's diagram of his magnetic sound recorder, shown here in the recording position. (From [2].)

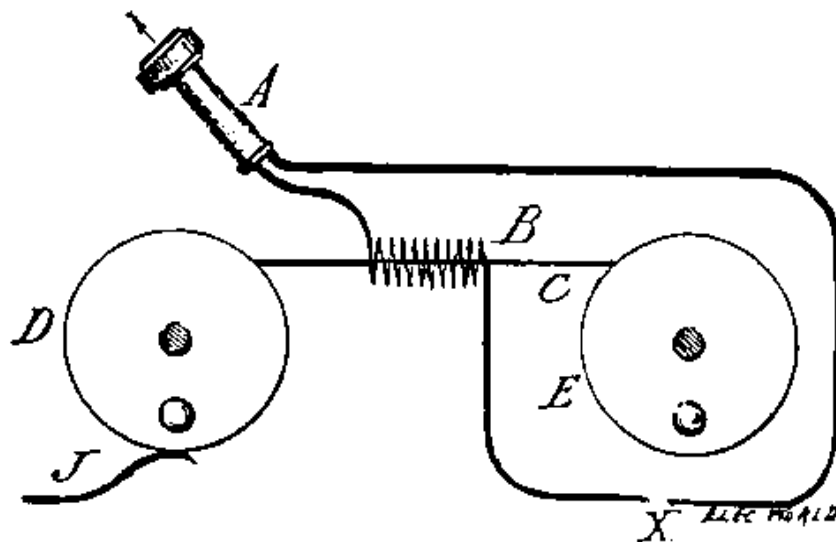

Fig 3. Smith's diagram of his magnetic sound recorder, shown here in the playback position. An amplifier ("intensifying apparatus") should be inserted at X. (From [2].)

During playback - for which, as Smith emphasizes, substantially the same components can be used as for recording - the telephone receiver A is the "loudspeaker," the electrical-acoustical transducer. The coil B, which is now the magnetic-electrical transducer, operates as an induction coil, that is, it translates magnetization into electrical voltage. Smith describes it like this:

To make the ...cord C "talk back" it is, after having been rewound on the reel D again drawn through a helix B, Fig. 3....Of course it is drawn through at approximately the same speed as before. In passing, the small permanent magnets in the cord C induce currents of electricity in their enveloping helix.... These waves of current will correspond in length and relative intensity with the original wave currents, and will therefore reproduce the vibrations of the original sound in the diaphragm... at any time in the future.

The vital words "at any time in the future" almost reproduce Edison's! The playback circuit is interrupted at X: Smith, farsightedly, thinks a modification here may be desirable or necessary:

...it may be possible to insert at X, Fig. 5, some intensifying apparatus... but which has not yet been thought out.

What is the nature of the sound carrier? Smith has an original proposal to make:

The probable construction of C would be a cotton, silk or other thread, among whose fibres would be spun (or otherwise mixed) *hard steel dust*, or short clippings of very fine steel wire, hardened.... Other forms of C might be a brass, lead or other wire or ribbon through which the steel dust was mixed in melting - being hardened afterward in the case of brass or any metal with a high melting point.

The hardening is perhaps intended to improve the corrosion behavior of steel. As regards the dimensions of the pieces of wire, Smith gives specific instructions:

Experiments with hardened steel wire, broken in a special machine into very short pieces, showed that they must not be too short - say not less than three or four times their diameter - or they could not be saturated with magnetism...

- a consequence of the self-demagnetization of relatively short bodies. Smith is conscious of the advantage of his sound carrier as regards both quality and economy:

The cord C therefore contains a perfect record of the sound, far more delicate than the indentations in the tin-foil of the mechanical phonograph.... The cotton thread above mentioned would seem to be preferable to anything else on account of its cheapness, lightness and flexibility.

Smith thus points the way to what, along with the phonograph disk, will be the most successful line of development. Briefly, he has invented magnetic sound recording. In the past the credit for this

invention has been given to the Danish engineer Valdemar Poulsen. It was certainly Poulsen who, from 1898 onward, was the first to achieve magnetic sound recording with mass-produced apparatus and to demonstrate it publicly. His contribution [5] cannot be denied. But the proper historical sequence of events requires that we should rewrite the opening chapter of the history of magnetic sound recording, since we now have satisfactory answers to justified questions that have been posed regarding Smith's work [6]-[9].

First question: Who and what was Oberlin Smith?

In the past we have been dealing with assumptions like: "To judge from his technical ideas he must actually have been a physicist who took the name Smith as camouflage" [9]. Recently, however, two short biographies and other published material have come to light. Smith was born 1840 March 22 in Cincinnati, OH, and died 1926 July 18 in Bridgeton, NJ. He was a successful mechanical engineer and owned a company called Ferracute. He applied for about 70 patents; in 1889 he was elected president of the American Society of Mechanical Engineers. His parents were born in England; his father was deeply committed to

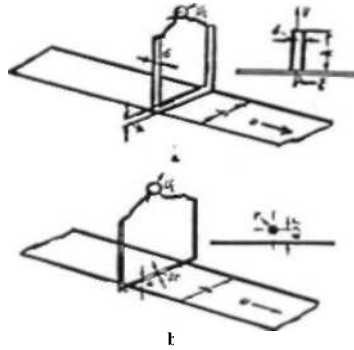

Fig. 4. Single- turn transducer for magnetic tape

the antislavery movement. Smith himself later shared this commitment, and was also an advocate of women's suffrage - clearly he was progressive personality not only in technical matters [10], 11. <sup>3</sup>

The second objection: The (relative) length of the coil B supposes a very high carrier speed [9]. This reservation is entirely justified. However, it can be traced to an error in the drawing. This is apparent from a hitherto unknown letter from Smith to the editor of *The Electrical World*, dated 1888 September 29 [12]. Smith writes: In cuts, Fig. 4 and 5, the helix should be shown very short, and possibly might consist of only one coil, as with the long helix represented it would be impossible to localize the magnetism in the way desired... - and it may be added, to store it at all. Modern literature [13] names the single-turn transducer (Fig. 4) as the physically simplest method of scanning a magnetic tape, and this very much resembles Smith's diagram (Fig. 5) as corrected in accordance with his instructions.

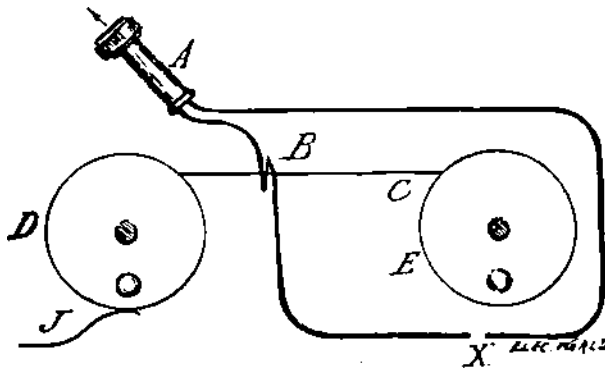

Fig. 5. Smith's diagram of his magnetic sound recorder, with the transducer dimensions corrected in accordance with his instructions of 1888 Sept. 29.

Third objection: The essay reads like an armchair study, an exercise in pure theory. If Smith conducted no experiments, he can hardly be called the inventor. In this instance. Smith's letter of 1888 September 29 provides a more than adequate answer:

At the time I experimented I also tried drawing the cord across the corner\* of an electro-magnet around which the helix was wound, instead of allowing it to act directly upon the cord. This would probably be a better way,...

\* sic in original: "corner" is probably a typo for "core."

- and so it would, since coil and core are elements of all present-day electromagnetic transducers. This not only provides proof of Smith's experimental work, but it also shows that he invented a second functional transducer. The additional data he supplies lead to an arrangement as shown in Fig. 6, which bears a great resemblance to Fig. 7. This shows the transducer configuration used in the 1930s to scan magnetic steel tape recordings [14] .

In light of this evidence other passages in Smith's study take on a new importance, such as the findings quoted above regarding the ideal

length of the magnetic particles. The appropriate paragraph (in "Some Possible Forms of Phonograph") starts with a confession and a remarkable item of information:

Like the two mechanical methods first mentioned, this electrical method has never been worked out to completion. The writer went far enough with it to build a temporary apparatus and to develop a successful machine for spinning metallic dust into a cotton cord, but was obliged to lay aside the whole thing before arriving at any *acoustic* results. (*Italics as in original.*)

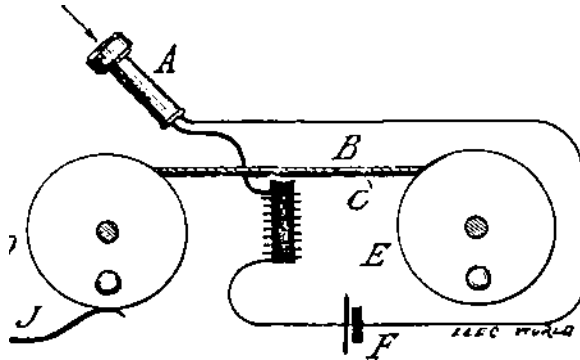

Fig. 6. Smith's diagram of his magnetic sound recorder, with the transducer redesigned in accordance with his instructions of 1888 Sept. 29.

Smith makes it clear that he regards the "recording telephone," in particular, as a practical proposition. This is apparent from Fig. 8, in which the magnetic sound recorder is incorporated into a telephone circuit, and a passage from which there is only a single step to the key phrase "data protection":

Of course the record might be made at the receiving instead of the transmitting end of the line, and thus our hypothetical young lady might, while listening to the impassioned pleadings of her chosen young man, be preparing the evidence for a future breach-of-promise suit.

The young lady has been introduced in order to clarify another aspect of the sound carrier:

The Lord's Prayer could be written upon a few feet of thread or string, while a young lady receiving a small spool of cotton from her lover would think herself abominably neglected if it was not "warranted 200 yards long."

Anyone with a similar sense of humor should be able to reconstruct from these data the speed at which Smith expected his sound carrier to operate. His ideas about magnetism are equally uncertain:

The writer confesses to a good deal of ignorance upon the subject, but he was somewhat surprised to find an equal amount in several well-known electricians whom he consulted; and also to



find that none of the books he had at hand gave any definite data regarding the best proportions for permanent magnets.<sup>4</sup>

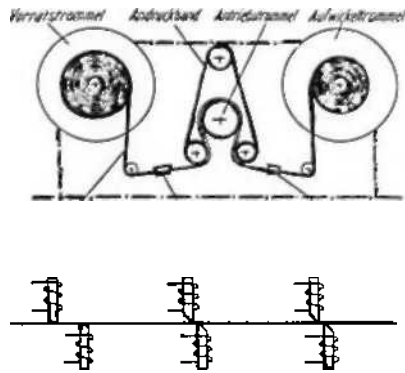

Fig. 7. Design of magnetic heads in the "steel-tape magnetic recording machine" [14].

Smith remains a realist, too, in his evaluation of his invention:

...it is possible that an insuperable objection to it would be found in the great diameter and length which would be required to hold magnets of sufficient strength and quantity. This, however, can be determined by experiment only. Of course if this cord approached a clothes line rather than a piece of sewing silk, in its general proportions it would be utterly useless as a practical recording medium.... One disadvantage of the cord is that if some small portion of the record near the middle has to be repeated there is a good deal of unwinding to do to get at it.... In practice, however, it might prove that this unwinding was a small matter, if a rapidly working automatic winder were used.

"Some Possible Forms of Phonograph" was cited against Smith as a prior disclosure when he attempted to apply for a patent for his invention, although he had already filed a caveat as early as 1883. This probably means that Smith had carried out his experiments five years before publishing the results, and this is supported by evidence in the text ("...which the writer contrived some years ago, but which were laid aside and never brought to completion...").

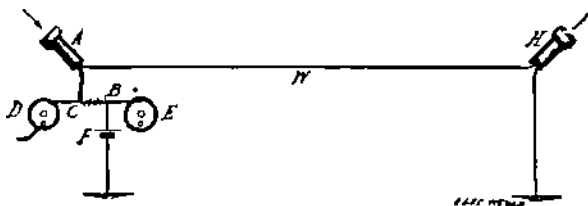

Fig. 8. Smith's magnetic sound recorder incorporated into a telephone circuit. (From [2].)

Smith was probably as unable as most of his contemporaries, including Edison, to recognize the full implications of his invention. Apart from two readers' letters to *The Electrical World*, which have little to add, there seems to have been no further reaction in the United States. (But who had what reason to cite "Some Possible Forms of Phonograph" as a prior disclosure?) A literal translation of Smith's article was published in France [15]. Did Poulsen read *The Electrical World*? So far as we know, he did not refer to Smith in any of his patents or publications, while Smith himself followed the course of events. In his 1904 biography we find the revealing sentence: "The invention has recently been taken up in Sweden and developed into commercial shape" [10].

Perhaps Smith's proposals were still ahead of their time. Even Poulsen's "Telegraphone" - some of which used steel wire, others steel tape - ultimately failed for lack of amplification equipment, which was not available until after 1910, by which time the Austrian Robert von Lieben had developed the vacuum tube, invented by the American Lee de Forest, into the low-frequency amplifier [16].

The question still remains: what results did Smith's experiments produce? Evidently, not "acoustic results" in the sense of sound signals, but couldn't the italicizing of "acoustic" express that Smith was somehow able to convince himself that signals were stored on his magnetic sound carrier? Did he perhaps use a circuit consisting of a battery and morse key as a "generator" to record dc pulses that were audible as crackling when played back? Only experiments could answer these questions, and the centenary of the publication of Smith's study and the addition of 1888 September 29 (or, at least, his 150th birthday in 1990) should be sufficient cause for such experiments to be conducted in the U.S.

Smith's essay was rediscovered in the United States by Semi J. Begun while he was working on his well-known book *Magnetic Recording* [6], [17]. In 1930 Begun, while working for C. Lorenz in Berlin, designed among other things the steel tape magnetic recording machine, the unjustly forgotten predecessor and competitor of the Magnetophon, 'the present-day analog tape recorder. From 1944 onward, in the United States, Begun constructed the Soundmirror tape recorder, independently of the German development of the Magnetophon, and many of these were sold by the Brush company. It was mass production of the audio tapes for the Soundmirror that gave 3M its foothold in magnetic tape technology.

Herman Hollerith, whose patents were also published 1888 September 8, enjoyed quicker and greater success than Smith. His counting and sorting machines were used successfully for the American national census as early as 1890. One curious sidelight: the results of the census were published with reluctance because the population of the growth-conscious United States had increased, since 1880, not by 30%, as was naturally assumed, but "only" by 25% [1].

## NOTES

\* Reprinted with the kind permission of the *Journal of the Audio Engineering Society*, Vol. 36, No. 3 (March 1988), pp. 170-178.

1. The heating of a "sound tape provided with a wax layer" was, however, regarded as patentable in 1938 (German Patent 747, 218). Mechanical sound recording was also carried out using tape-shaped carriers, as, for example, in the "Tefiphon," which was on sale in West Germany until around the end of the 1950s.
2. Today's magnetic pigments are 10 times as long as they are thick, due to target-oriented development. The higher the coercivity of the storage medium, the more the storage density can be increased. Regarding the use of a thread with included pigments, compare Smith's information with German Patents 831,459 and 811,508 (BASF, 1949). Filament-Shaped Carriers Coated (Not Interspersed) with Magnetic Pigment."
3. We are grateful to Dr William Lafferty, Wright State University, Dayton, OH, for drawing out attention to [10] and [11].
4. Acicular magnetic pigments were not developed until about 1950. Carbonyl iron (1932-1936) is spherical; iron oxides Fe<sub>3</sub>O<sub>4</sub> (1936-1939) and Fe<sub>2</sub>O<sub>3</sub> (from 1939) were initially used in the form of cubic pigments.
5. A caveat (under statutory regulations in effect up to about 1907) is filed in the patent office. The principal object of filing it is to obtain for an inventor time to perfect his invention without the risk of having a patent granted to another person for the same thing. In the practice of patent law, a caveat means a legal notice serving the purpose not to issue a patent of a particular description to any other person without allowing the caveator (one who files a caveat) an opportunity to establish his priority of invention. See [10].
6. More accurately, in Denmark.
7. A comprehensive description of the "steel-tape era," particularly the simultaneous, independent development of the Marconi-State tape recorder and Dr Begun's steel-tape sound recording machine, will be found in [5] and [18].

## REFERENCES

- [1] H. Zemanek, "Hollerith und Schäffler - Datenverarbeitung um 1890, Drei Nationen werden elektrisch gezählt" (Hollerith and Schäffler - Data Processing around 1890, Electrical Censuses in Three Nations), in *Elektrotechnik im Wandel der Zeit (Electrical Engineering over the years)*, H.A. Wessel, Ed. (VDE-Verlag, Berlin/Offenbach, 1986), p.96.
- [2] O. Smith, "Some Possible Forms of Phonograph," *The Electrical World*, pp. 161 ff. (1888 Sept. 8). All quotations not otherwise attributed are taken from this source. The Library of the Swiss Federal College of Technology (ETH), Zurich, Switzerland, has a copy of the 1888 volume.
- [3] *Elektrotechn. Z.* (Germany), p. 169 (1889 Mar.). The text was published *inter alia* by Marvin Camras in his book *Magnetic Tape Recording* (Van Nostrand Reinhold, 1985), so that it is accessible to a wider audience.

- [4] W.L. Welch, "Edison and His Contributions to the Record Industry," *J. Audio Eng. Soc.*, vol. 25, pp. 660-665 (1977 Oct./Nov.).
- [5] W. Ch. Lafferty, "The Early Development of Magnetic Sound Recording in Broadcasting and Motion Pictures," Ph.D. Dissertation, Evanston, IL, 1981.
- [6] S.J. Begun, *Magnetic Recording* (Rhinehart, New York, 1949), p.2.
- [7] J. Klinkmüller, "Zur Geschichte der elektromagnetischen Schallaufzeichnung" (On the History of Electromagnetic Sound Recording), *Elektrotechn.*, Z. A, vol. 76, no.3, pp. 48-50 (1955).
- [8] P.A. Zimmerman, "Oberlin Smith, ein vergessener Erfinder" (Oberlin Smith, a Forgotten Inventor), *Die BASF* (house organ of BASF AG), p. 146 (1957).
- [9] W. Bruch, *Von der Tonwalze zur Bildplatte (From the Sound Cylinder to the Video Disk)*, pt. 2 (Franzis Verlag, Munich, 1983) pp. 9-14.
- [10] *The National Cyclopedia of American Biography*, vol. 12 (James T. White & Co., New York, 1904) p. 461. Pertinent text is republished in AES preprint 2550 (F-1).
- [11] *Who Was Who in America*, vol. 1 (The A.N. Marquis Co., Chicago, 1943), p. 1147. Pertinent text is republished in AES preprint 2550 (F-1).
- [12] O. Smith, letter to the editor. *The Electrical World*, p. 179 (1888) Sept. 29). Pertinent text is republished in AES preprint 2550 (F-1).
- [13] O. Schmidbauer, "Vorgang der Magnetton- Aufzeichnung und Wiedergabe" (Magnetic Sound Recording and Reproduction), in F. Winckel, Ed., *Technik der Magnetspeicher (Magnetic Storage Technology)*, 1st ed. (Springer, Berlin, 1960), p. 48.
- [14] H.-J. von Braunmühl, "Der heutige Stand der Schallaufnahmetechnik und ihre Anwendung beim deutschen Rundfunk" (The Present State of Sound Recording Technology and Its Application in German Radio), *Akust. Z.*, pp. 250 ff. (1938).
- [15] J. Wetzler, "Le Phonographe; La Lumière Electrique" (The Phonograph; The Electric Light), quoted in [9, pp. 592-594].
- [16] R. von Lieben, E. Reisz, and S. Strauss, German Patent 249,142 (1910 Dec. 20).
- [17] S.J. Begun, personal communication, 1986 Dec.
- [18] W. Lafferty, "The Use of Steel Tape Recording Media in Broadcasting," *SMPTE J.*, pp. 676-682 (1985 June).